

Specialised System Components for Milk of Lime Processing Plants



Lime Dosing

Lime Dosing

WAMGROUP® offers specialised system components tailored to the specific requirements of project engineers of milk of lime processing plants. By selecting this specialised equipment, system designers have the assurance they will combine top quality and performance with the highest possible operating efficiency.

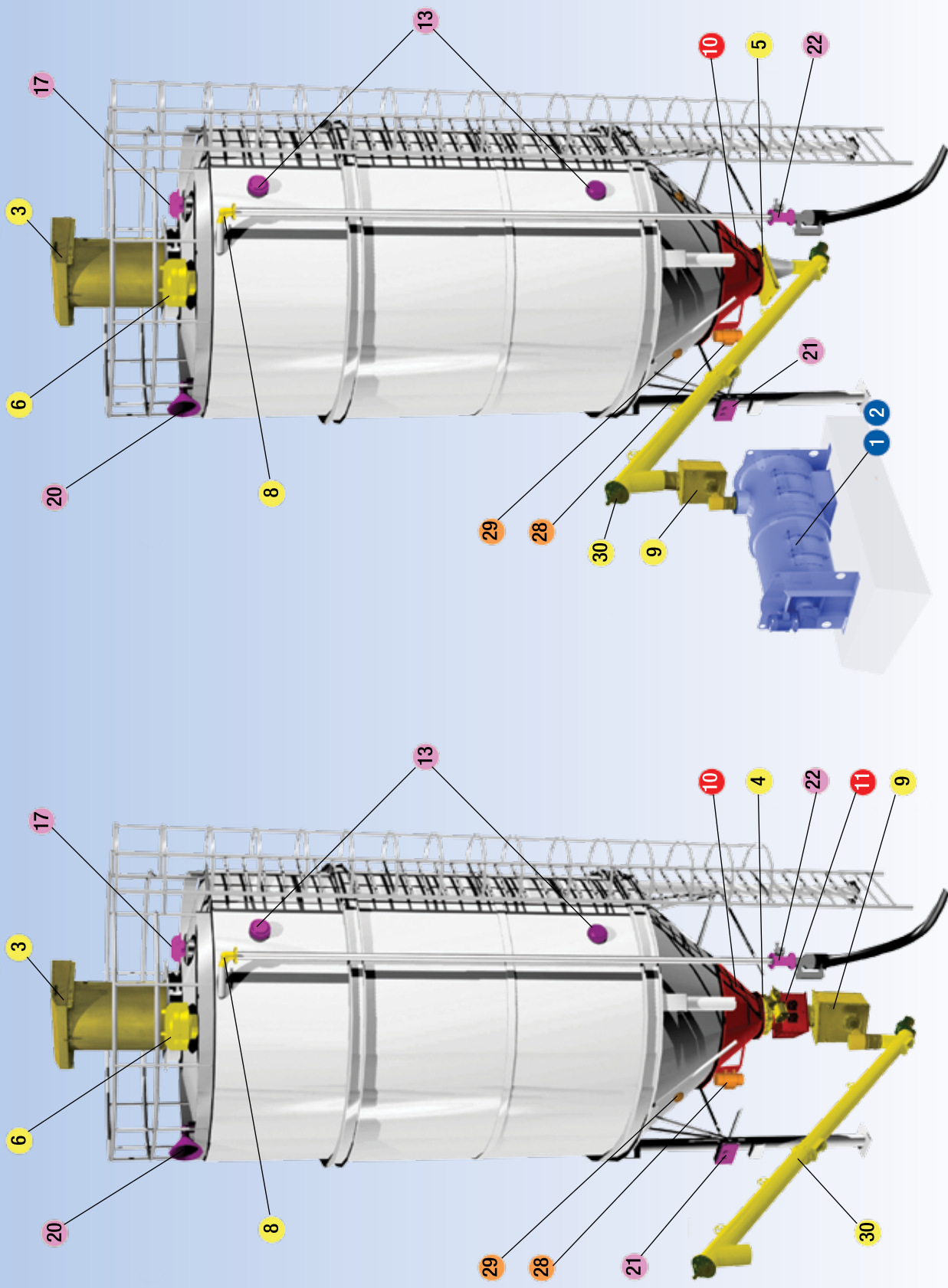

1 Continuous Single Shaft Mixers WAH
High productivity



2 Continuous Twin Shaft Paddle Mixers MESC
Easy and quick installation



3 WAMFLO® Silo Venting Filters
Easy filter element replacement



4 Butterfly Valves VFS
Easy and quick maintenance



5 Slide Valves VL
No seal adjustment required



6 VCP Spring-Loaded Pressure Relief Valves
*Optimum work safety:
ATEX zone 21-certified*



7 Polymer Pressure Relief Valves VHS-C
Safety for people, plant and environment



8 EXTRABEND® & EXTRACURVE® Pipe Elbows
*Abrasion-resistant
lightweight design*



9 Micro-Batch Feeders MBF
High feeding accuracy



10 Bin Activators BA
Discharging of lime from silo



11 Lump Breakers DLP
Perfect de-lumping



12 Manual Bag Openers RSM
Minimum-residue design



13 Drop-Through Rotary Valves RV - RVR
Air-purged seals



14 Rotary Level Indicators LIT
Easy to install



15 Continuous Level Indicator ILS
Easy to install



16 Vibrating Level Indicators ILV
Easy to install



17 Probe Level Indicator ILK
Easy to install



18 Differential Pressure Meters & Gauges IPE / IPM
Versatile and Economic



19 Silo Safety System KCS
One control panel for up to 16 silos



20 Siren LSI
Malfunctioning alarm



21 Power Panel SP
*Part of KCS-System;
one panel per silo*



22 Pinch Valves VM
Easy to install



23 Drum-Type Diverter Valves for Pneumatic Conveying VAR
Easy to install



24 Diverter Valves for Pneumatic Conveying VAD
Easy to install



25 Flap Diverter Valves VAB
*Quick integration
into the process*



26 Drop-Through Rotary Valves RVC
Easy maintenance



27 Blow Through Rotary Valves RVS
Easy Maintenance



28 External Electric Vibrators
ATEX zone 22-compliant



29 Vibrating Bin Aerators VB
For all powdery materials



30 Screw Conveyors TU
Sturdy design





UNI EN ISO 9001
Certified Company



063002418 May 2014 Rights reserved to modify technical specifications.



www.wamgroup.com